

Registration  
for the  
23-24  
School Year

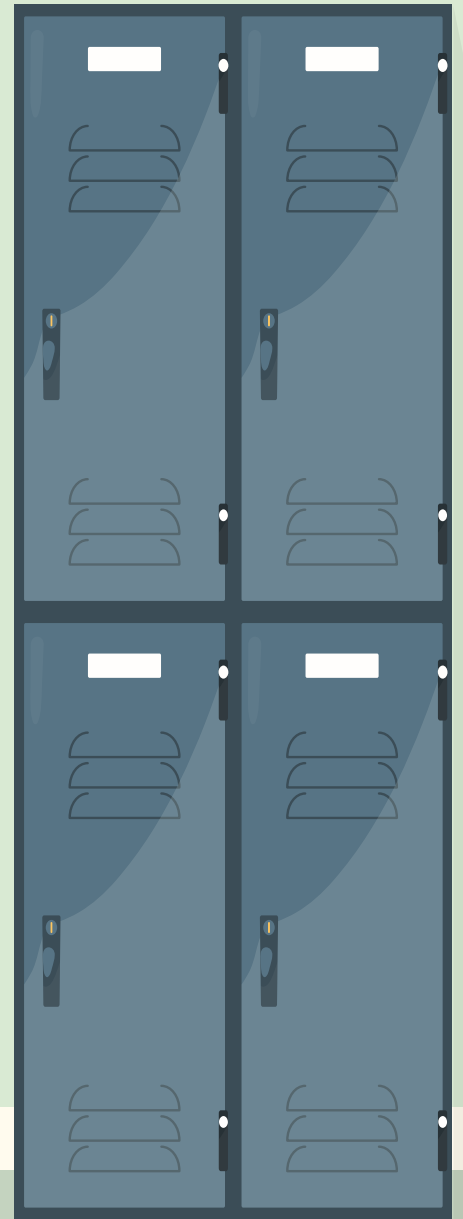

# For Today

We will:

- Learn about classes for next year
- How to fill out your google registration form
- Deadline for turning in the registration form
- How to get more information if you have questions

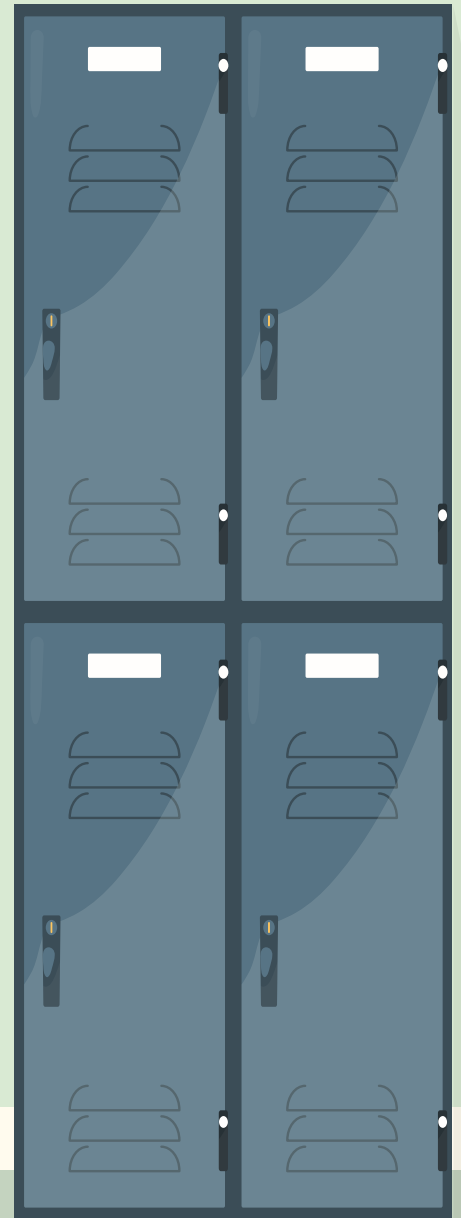



# LET'S TALK ELECTIVES!

## Think about:

What are my interests?

What would I like to learn more about?

Think ahead to HS and Post-HS  
interests when deciding

\*Remember: We require students to take at least one technology and one fine arts class before leaving Middle School to allow for a well rounded curriculum. So if you have not taken one of those in middle school, please register this year\*



# Technology Electives

## Year Long Courses

### 8th Grade Only

- Intro to Engineering/Design (\*)
- Foundations of Computer Science (\*)

## Semester Courses

### 8th Grade only

- Invent the Future (--)

\* High school credit class which qualify for your technology credit in high school

-- Does not qualify for high school credit

# Foundations of Computer Science\*

High School Credit Course

Scratch

- Program Robots



Use the Design Process to solve problems.

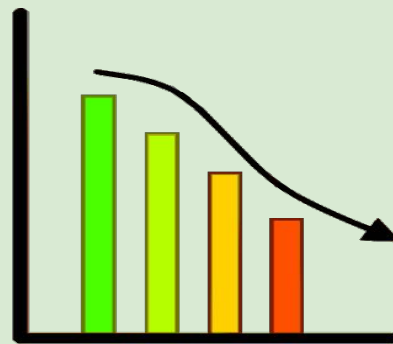

Analyze Data

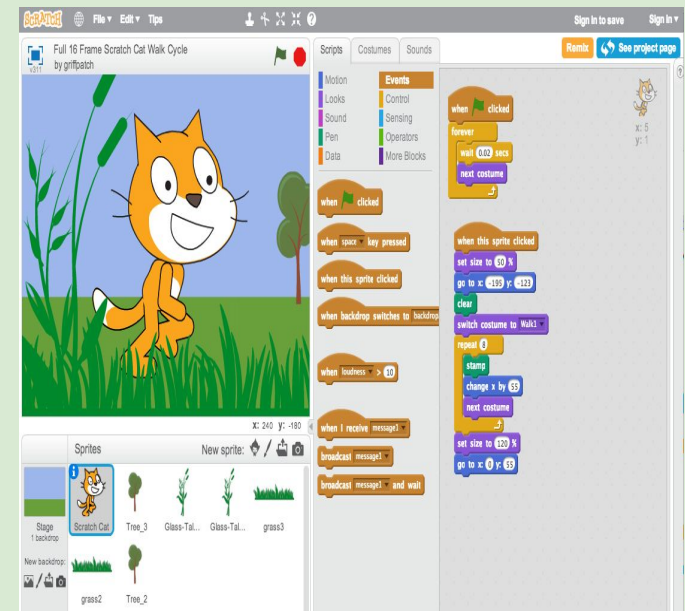

Computer Programming

Create a Web page using HTML / CSS

# Intro to Engineering Design (IED)\*

8th graders recommended for Algebra or Geometry

First course in the Project lead the Way Engineering Program at Rockville High School.

The major focus of the IED course is to expose students to design, 3D modeling, teamwork, communication methods, global and human impacts, engineering standards, and technical documentation.

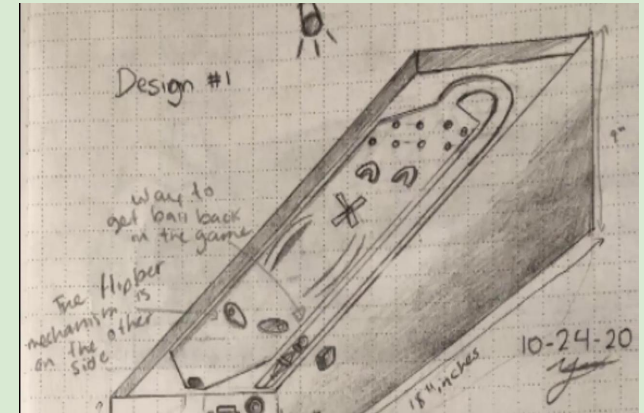

*Fulfills High School Tech Ed credit*

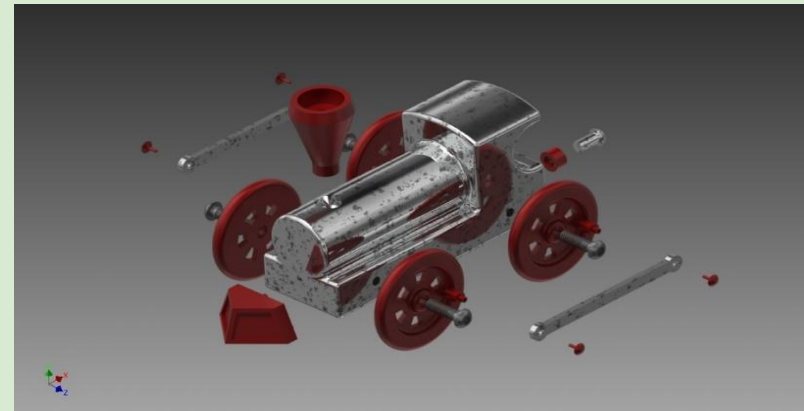
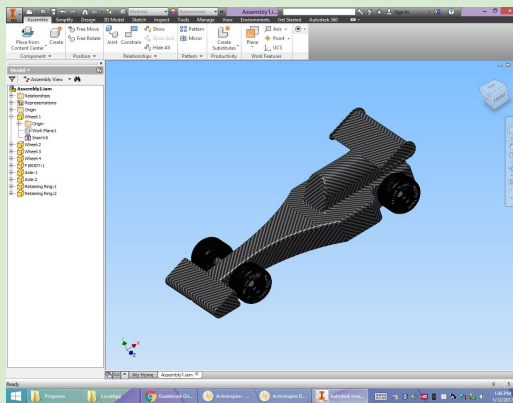

# Invent the Future (8th)

This class is run in partnership with the Kid Museum

Students will:

- Use computer science and engineering design through hands on, project based learning experiences that bring together technical skill building and creative problem solving.





# Art & Career Electives



## Year Long Courses

- Studio Art 3
- Theater 2
- Instrumental Classes (Band/Orchestra/Chorus)
- World Language (Spanish/French)\*
- Student Court
- Student Aide
- Autism Buddy – PE

## Semester Courses

- Studio Art 3
  - Digital Art & Photography 3
  - Theater 1
  - General Music 1
  - Music Tech
  - Forensics
  - Autism Buddy – Art/Tech/Music
- 



# DIGITAL ART & PHOTO 3

- Explore and develop your own creative workflow!
- Experiment with a variety of photographic techniques
- Edit, create, and develop a portfolio of artwork to share!

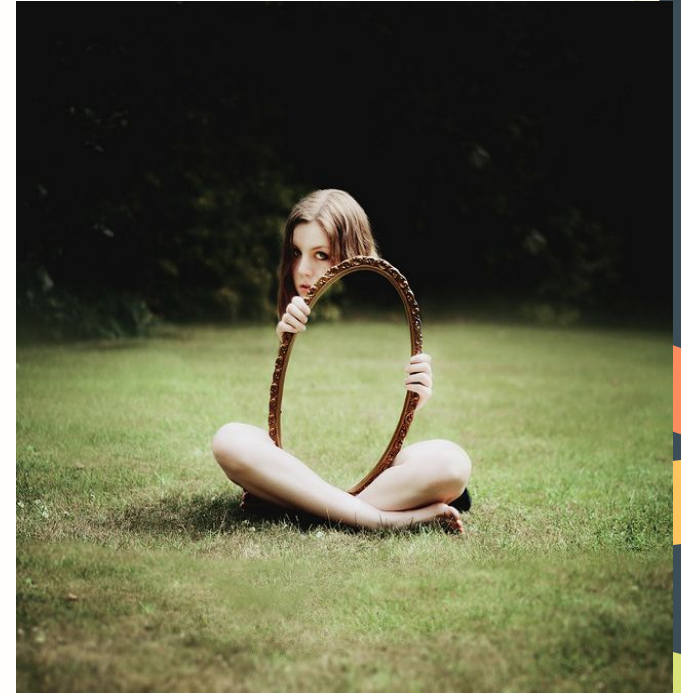

Open to **8th**  
grade students!

LEARN MORE ABOUT DIGITAL ART + PHOTO!



Contact: **Jacob\_F\_Hicks**@mcpsmd.org



# Art Studio 3

Using a variety of media and techniques students will explore big ideas connected to influence.

Artists will use sketchbooks and work with charcoal and conte drawing, mixed media portraits, acrylic research painting, incised printmaking, ceramic slab construction and use the pottery wheel.

Artist will use vocabulary to analyze and critique artwork through discussion and writing. All students will participate in art shows and attend a Glenstone field trip !



# Theatre 1 & 2

*Students who have taken Theatre 1 may take Theatre 2*

## Play on!



- Improvisation
- Playwriting
- Monologues
- Scene Performance
- Theatre History

“Suit the action to the word, the word to the action!”

**General Music, Music Technology  
&  
Chorus  
with Mrs. Cox**

**Instrumental Music  
with Ms. Price**



# General Music 1

One semester course

*Listen to music every day!*

*Tech-based learning*

*Popular music history: blues, jazz, rock, rap, pop, country, disco, kpop, and more!*

## General Music is for everyone!

- All 6th, 7th, and 8th graders can take this beginning level class!
- This is a great option if you love music, but don't want to perform.
- You can try music for one semester and try something else the second half of the year.

[bree.h.cox@mcpsmd.net](mailto:bree.h.cox@mcpsmd.net)

# General Music 3: Music Technology

One semester course

*Composition and Music Theory*

*Tech-based learning*

*Podcasting and Voice Over*

*Looping and Mixing Music*

*Create music to share with friends*

## Recommended qualifications:

- 6th Graders: nominated by your elementary school music teacher
- 7th and 8th graders: have taken a music class (Band, Orchestra, Chorus, or General Music I)
- You have not previously taken this class.

[bree.h.cox@mcpsmd.net](mailto:bree.h.cox@mcpsmd.net)

# Chorus I, II, & III

Full-year courses

*Lots of performance opportunities*

*Field trips to sing outside of school*

*Solo opportunities*

*Learn lots of fun music from pop, musicals,  
classical and foreign language!*

*Zoo Lights, Hersheypark, and Six Flags\**

*\*Chorus II & III only*

**Not sure which one to register for?**

## Chorus I - Treble Makers

- All incoming 6th Graders

## Chorus II - Name TDB

- Rising 7th Graders
- Rising 8th Graders new to chorus

## Chorus III - Rhapsody in Blue

- 8th Graders who have completed 2 years of chorus
- 7th Graders by audition

[bree.h.cox@mcpsmd.net](mailto:bree.h.cox@mcpsmd.net)





# Instrumental Music

Open to all 6th, 7th, & 8th graders!

## Beginning Band

All Band Instruments Include:

Flute, Oboe, Bassoon, Clarinet, Saxophone, Trumpet, French Horn, Trombone, Baritone, Tuba, Percussion (Drums, Mallets, etc).

Click [\*\*HERE\*\*](#) for a video introduction to all Instrumental Music classes

Interested in learning a new instrument or wanting to continue from elementary school? These are the groups for you!! These are **FULL YEAR** courses

## Beginning Orchestra

Orchestra Instruments Include:

Violin, Viola, Cello, Bass

## Beginning Ensembles perform for...

- Schools concerts (Winter, Cluster, & Spring)
- The opportunity to audition & perform for the Music in the Parks festival competition
- Honors Band & Honors Orchestra county ensembles (*optional*)

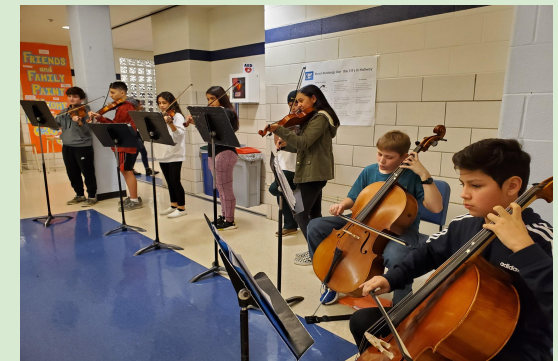

## Intermediate Band

\*Enrollment based on recommendation by elementary band teacher.

# Instrumental Music



These are FULL YEAR courses!



## Band 1

### (Intermediate Band)

This class is for 6<sup>th</sup> graders and rising 7<sup>th</sup> and 8<sup>th</sup> graders who have completed at least one year of band in middle school

## Band 2

### (Advanced Band)

This class is for rising 7<sup>th</sup> and 8<sup>th</sup> graders who have completed at least one year of band in middle school and have been recommended by Mrs. Price

## Orchestra 2

### (Advanced Orchestra)

This class is for rising 7<sup>th</sup> and 8<sup>th</sup> graders who have completed at least one year of orchestra in middle school and have been recommended by Mrs. Price

### Advanced Band & Orchestra students perform for...

- All schools concerts (Fall, Winter, Cluster, & Spring)
- Marching Band Night at Rockville HS
- MCPS District Band/Orchestra Festivals
- Music in the Parks festival competition
- Honors Band & Orchestra county ensembles (*optional*)



# World Language Electives

*All World Language courses earn High School Credit*

Spanish 1  
Spanish 2  
Honors Spanish 3

- Spanish Literacy for Spanish Speakers 1
- Spanish for Spanish Speakers 1

French 1  
French 2  
Honors French 3



## WHY SHOULD KIDS LEARN ANOTHER LANGUAGE?



Look at all you can do when you study a world language!!!

*Students may take a placement test to bypass a level of a language or enroll in SSS. SSS classes are for 7th and 8th graders only.*

# Interested in IB Program for High School?



International Baccalaureate  
Baccalauréat International  
Bachillerato Internacional

Keep in mind:

**\*\*Students should be enrolled in Algebra and a World Language by 8th Grade**



There will be information nights in the fall to learn more about IB programs at Rockville and Richard Montgomery.



# Forensic Science

## Requirements of a Forensic Scientist

- Good communication skills
- Able to remain unbiased when checking evidence
- Meticulous by nature
- Logical thinker
- Motivated to learn and challenge ideas
- Excellent observation skills



## Forensic Science Topics

- History of Forensics
- Famous Court Case Studies
- Crime Science Investigation
- Identifying suspects
- Tracing Evidence
- Fingerprinting
- Blood Evidence
- Forensic Anthropology
- Bringing evidence to court

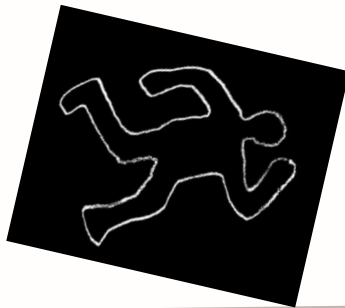

# Student Court

## STUDENT COURT

### Ever wonder...

- why lawyers say, "objection"?
- how a jury is picked?
- the difference between first-degree murder and second-degree murder?

### Are in interested in:

- becoming a lawyer?
- becoming a judge?
- going into law enforcement?
- acting?



IF YOU ANSWERED **YES** TO ANY OF THESE QUESTIONS, THEN THIS IS A CLASS YOU SHOULD SIGN UP FOR!!



### What you can expect to learn:

1. The United States Court system
2. Types of crimes
3. Criminal trial procedures
4. How and when to call Objections
4. The role of a jury
5. Opening/Closing Statements
6. **MOCK TRIALS**
7. And Much More!!

# Student Aide

Student Aides spend one period a day for the entire year helping out in the Main office, Counseling Office or Media Center instead of an elective class.



- Make deliveries to classrooms
- Help new students
- Shelf/Sign out books
- Run errands
- Prepare or laminate materials

MUST be Responsible, Mature and no Referrals

8th Grade students may apply to be a student aide by submitting an application, including teacher recommendations in March.





# Autism Buddy

Buddies spend one period a day for the entire year (PE) or semester (Art/Tech/Music) helping students in Wood's Autism class participate in their elective class.

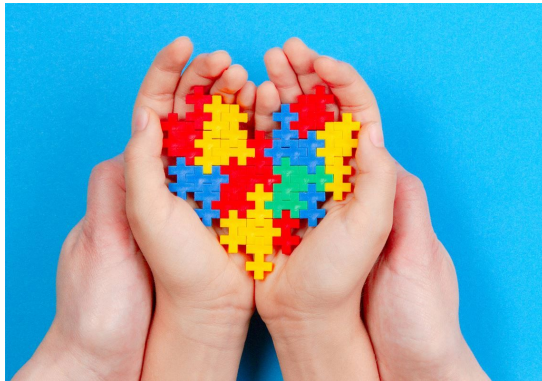

- Be a friend
- Share enjoyment for a class that you find fun
- Support students who may learn differently than you.

MUST be Responsible, Mature and no Referrals

7th or 8th Grade students may apply to be a buddy by submitting an application, including teacher recommendations in March.

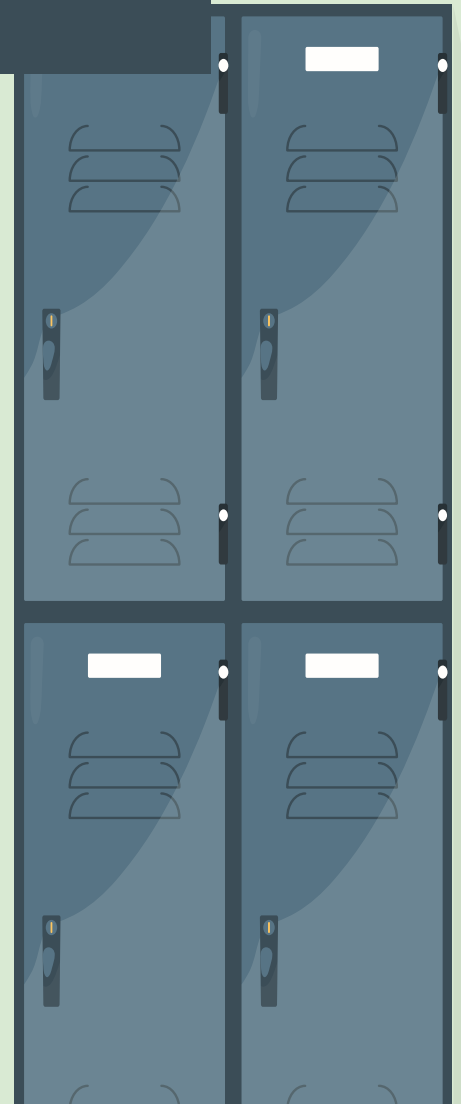



Counselors will be visiting Math classes the week of Jan 30th to work with you on completing the google form as a final step in the registration process

## Wood Middle School SY23 Rising GRADE 8 Electives Request Form Due by January 26th

Wood Middle School will be using Google Forms to obtain course requests for electives/world languages for the 23-24 school year. An registration card should have been sent home sharing the courses your student has been recommended for already. The following form should be used to request electives (including languages). Please contact the counseling office at 240-740-7650, or email Ms. Bostick ([Elizabeth\\_B\\_Bostick@mcpsmd.org](mailto:Elizabeth_B_Bostick@mcpsmd.org)) or Ms. Mehr ([Cara\\_F\\_Mehr@mcpsmd.org](mailto:Cara_F_Mehr@mcpsmd.org)) with questions.

Presentation will be posted on the Counseling Tab of the Wood Website by the end of the week.

Don't forget to talk with your parent or guardian about your choices before you submit!

Did you review your course selections with a parent/guardian? (this is required prior to submission) \*

- Yes
- No

# Rank your choices from 1-6

- 1= The elective you want most
- 2= Second most preferred
- Continue ranking through ...
- 6= The elective you want least

First Choice: Choose your most preferred course; Primera elección: Elije un curso mas preferido \*

Choose

 This is a required question

Second Choice: Choose your second most preferred course; Segunda opción: Elija su segundo curso preferido \*

Choose

Third Choice: Choose your third most preferred course; Tercera opción: Elija su tercer curso preferido \*

Choose



# Rising 8th Grade Registration Process- Next steps?

- Talk to your caregivers about what classes you are interested before submitting the form.
- Please write your math teacher's name and period on the corner of your registration form. **You will turn in these forms to your math teacher by Jan 26th.**
- Counselors will visit your math classes the week of Jan 30th to collect your forms and assist with completing the google form as a final step in the process



If you have questions about electives, please contact Ms. Bostick or Mrs. Mehr before January 26th,



EARLE B. WOOD MS



# RISING 7TH & 8TH GRADE PARENT NIGHT

JANUARY 18, 2023  
6:30-8:00 PM

WHERE: WOOD MS CAFE

Join us online as well through Zoom. Zoom link will be posted on our Wood website closer to the event.

Come join us for an informative meeting about registration. We will share the following:

- course request process,
- articulation timeline,
- course overview

Respectful, Responsible,  
and Ready to Learn



